

concerto™

Installation Instructions

Models ZZXX0662, ZZXX0662S,
450-5, 450-5BD and 200203441

Concerto™ Large Cabasa
In-ground and Surface Mount Models

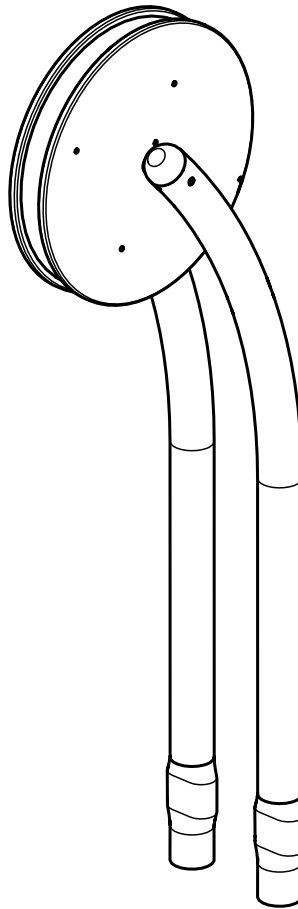

Assembly View (*representative model*)

Installation Preparation

Recommended Crew: Two (2) adults
Installation Time: 1.5 man-hours (In-ground)
Installation Time: 0.5 man-hours (Surface Mount)
Concrete Required: 0.26 cubic yard (0,20 cubic meters)
User Group Age (years): ASTM/CSA: 2-12, EN: 2-14

Installation Instructions

KEY	
Position	Unit of Measurement
Top #	Inches
Bottom #	[Millimeters]

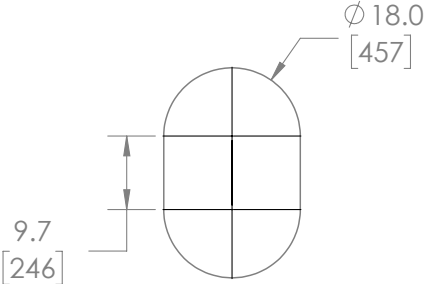

Footings Diagram

Top View

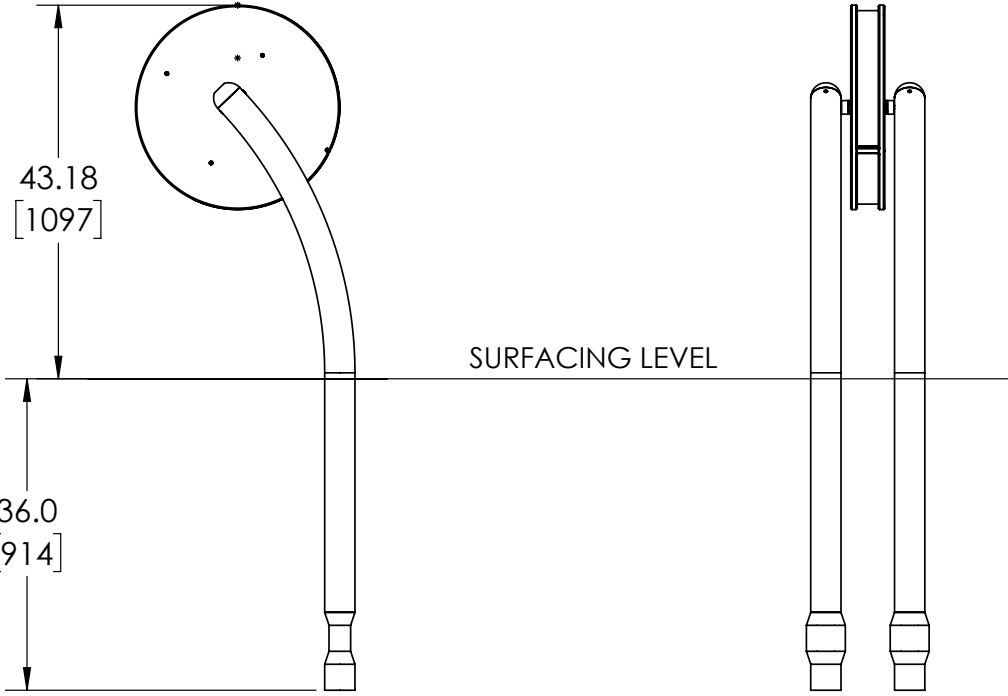
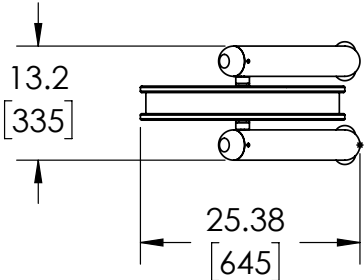

Elevation Views

ZZXX0662, 450-5 and 200203441

Installation Instructions

KEY

Position	Unit of Measurement
Top #	Inches
Bottom #	[Millimeters]

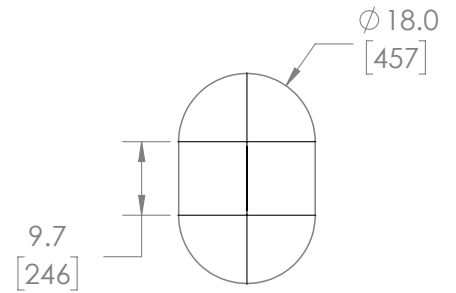

Footing Diagram

Top View

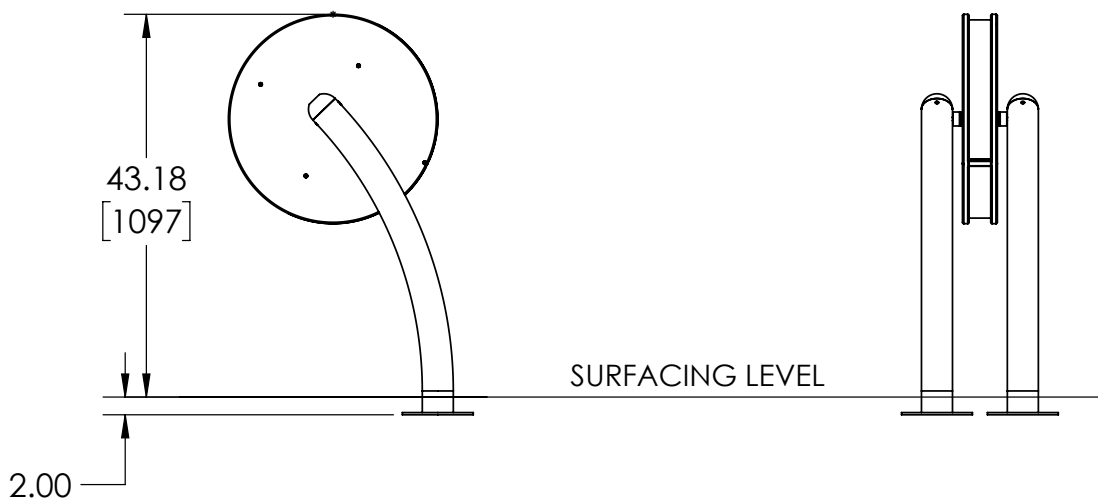
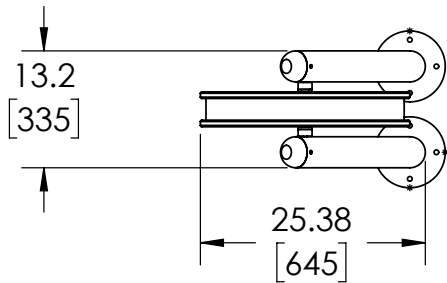

Elevation Views
ZZXX0662S, 450-5BD and 200203441

Installation Instructions

IN GROUND FOOTING DIAGRAMS: ASTM / CSA

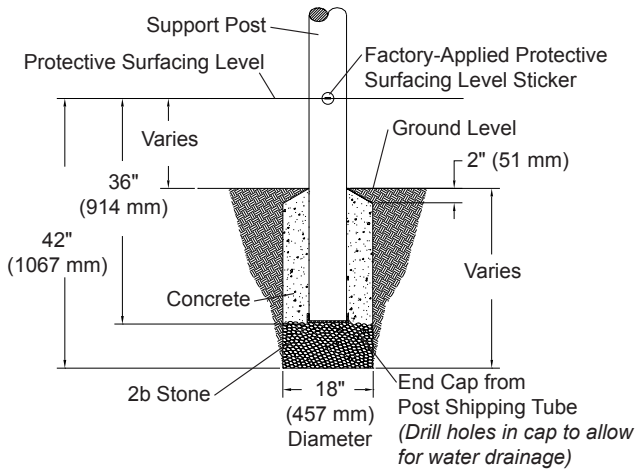

Support Post Footing Detail (ASTM/CSA)

IN GROUND FOOTING DIAGRAMS: EN (EUROPE ONLY)

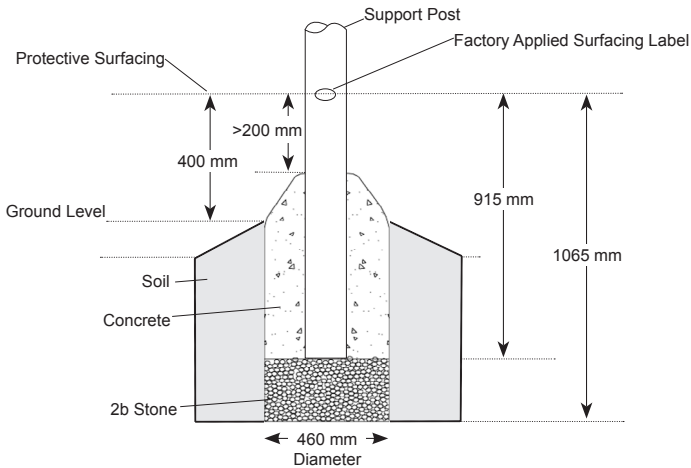

Footing Detail Support Post (EN)

FOOTING NOTES

- Support post footing depth equals 42 in. (1067 mm) less the depth of the protective surfacing material. The post is designed to have 24" (610 mm) in concrete.

Example: If 12 in. (305 mm) of wood mulch is used for surfacing, the footing depth would be 30 in. (762 mm).

- Most support posts and component support legs will have either a factory-applied sticker with line, or factory-applied mark designating protective surfacing level on a clear and level installation site.

- If play structure is installed on uneven terrain, maintain support post mark at protective surfacing level at lowest grade. Adjust other footings accordingly. Support posts and all attaching decks and play components must be plumb and level.

- Do not encase bottom of support post in concrete. Place post directly on packed stone.

- The footings shown on this documentation are recommendations based on historical performance in average soil conditions. Footing dimensions may be modified by the owner based on actual soil conditions.

For example:

- If local soil is loose or unstable, a larger footing may be required.

- If local soil is considered stable, such as bedrock, clay or hard packed earth, a smaller footing may be used. Before changing footing dimensions, we strongly recommend that the footings be reviewed and approved by a registered engineer.

- Base of footing must be below frost line.

- Assemble the entire structure before pouring concrete unless specifically instructed to do so in the individual component installation instructions.

Installation Instructions

SURFACE MOUNT FOOTING DIAGRAMS: SUPPORT POSTS AND COMPONENTS

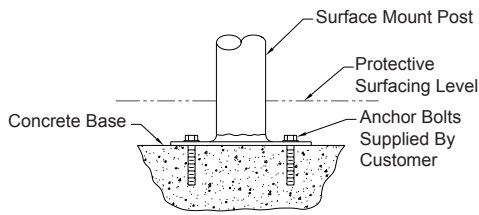

Surface Mount Footing Detail

DEFINITIONS

- **Concrete Pier:** A pier type surface mount installation is defined as a footing hole that has been excavated and poured with concrete. Concrete should be flush to the top surface of excavated hole. Equipment would then be secured to this concrete footing that has been properly cured.
- **Concrete Slab:** Existing concrete slab type installation is defined as equipment being secured to an existing concrete pad or slab. As an example, this pad could be in the form of an existing concrete parking lot.

FOOTING NOTES: PIER TYPE SURFACE MOUNT





- Most support posts and component support legs will have either a factory-applied sticker with line, or factory-applied mark designating protective surfacing level on a clear and level installation site.
- If play structure is installed on uneven terrain, maintain support post mark at protective surfacing level at lowest grade. Adjust other footings accordingly. Support posts and all attaching decks and play components must be plumb and level.
- Footing size may vary due to local soil and weather conditions.
- Base of footing must be below frost line.

FOOTING NOTES: EXISTING CONCRETE SLAB TYPE SURFACE MOUNT

- Most support posts and component support legs will have either a factory-applied sticker with line, or factory-applied mark designating protective surfacing level on a clear and level installation site.
- Support posts and all attaching decks and play components must be plumb and level.

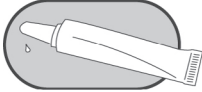
IMPORTANT NOTE: Surface mount hardware is not supplied. The customer is responsible for the concrete base and providing surface mount hardware as specified by a registered structural engineer for each specific project application.

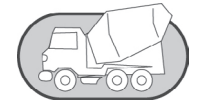
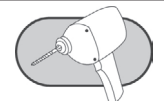
Installation Instructions

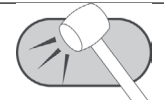
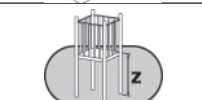
ICON KEY	
	Fully Tighten Hardware
	Add 1 Drop of Thread Locking Adhesive
	Do Not Fully Tighten Hardware
	Pour Concrete
	Drill
	Dig Footing Holes
	Hammer
	Critical Fall Height

Installation Instructions:

1. Prepare footings as shown on pages 4 and 5 of this document.
2. Assemble equipment as shown.
3. Place equipment in, or on, its footings and block and brace.
4. Plumb and level equipment and tighten all hardware.

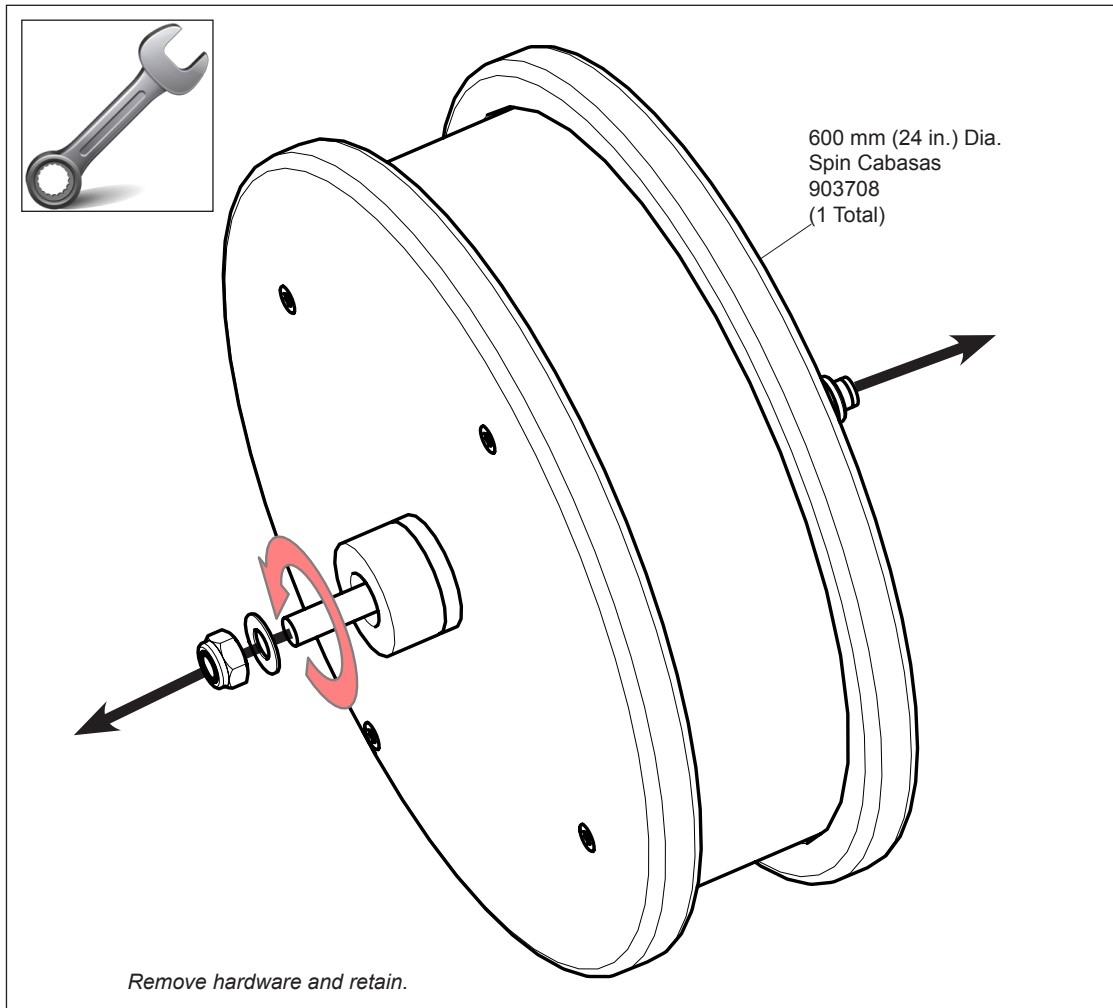

Installation Instructions

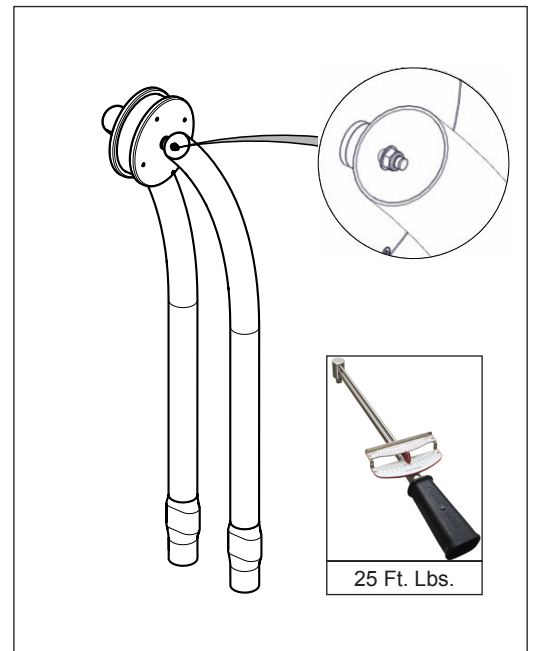
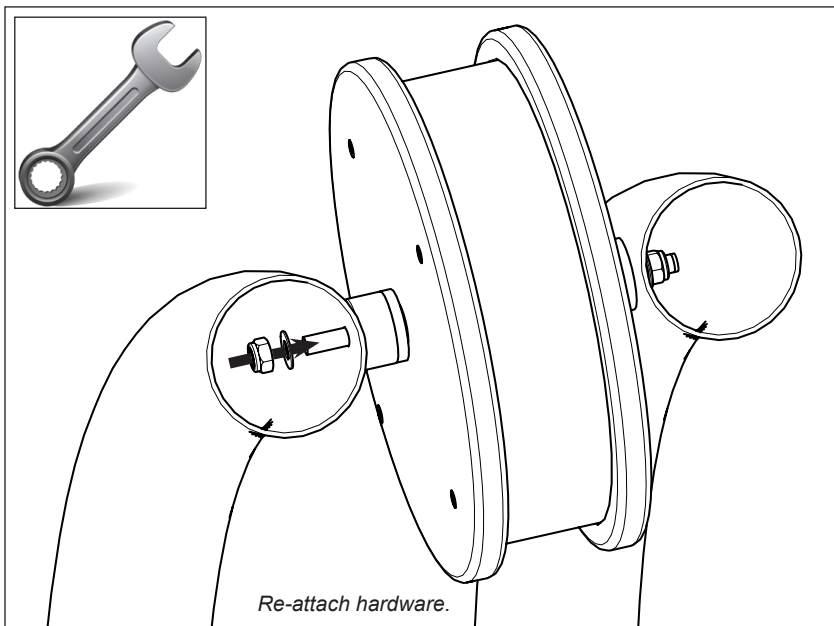
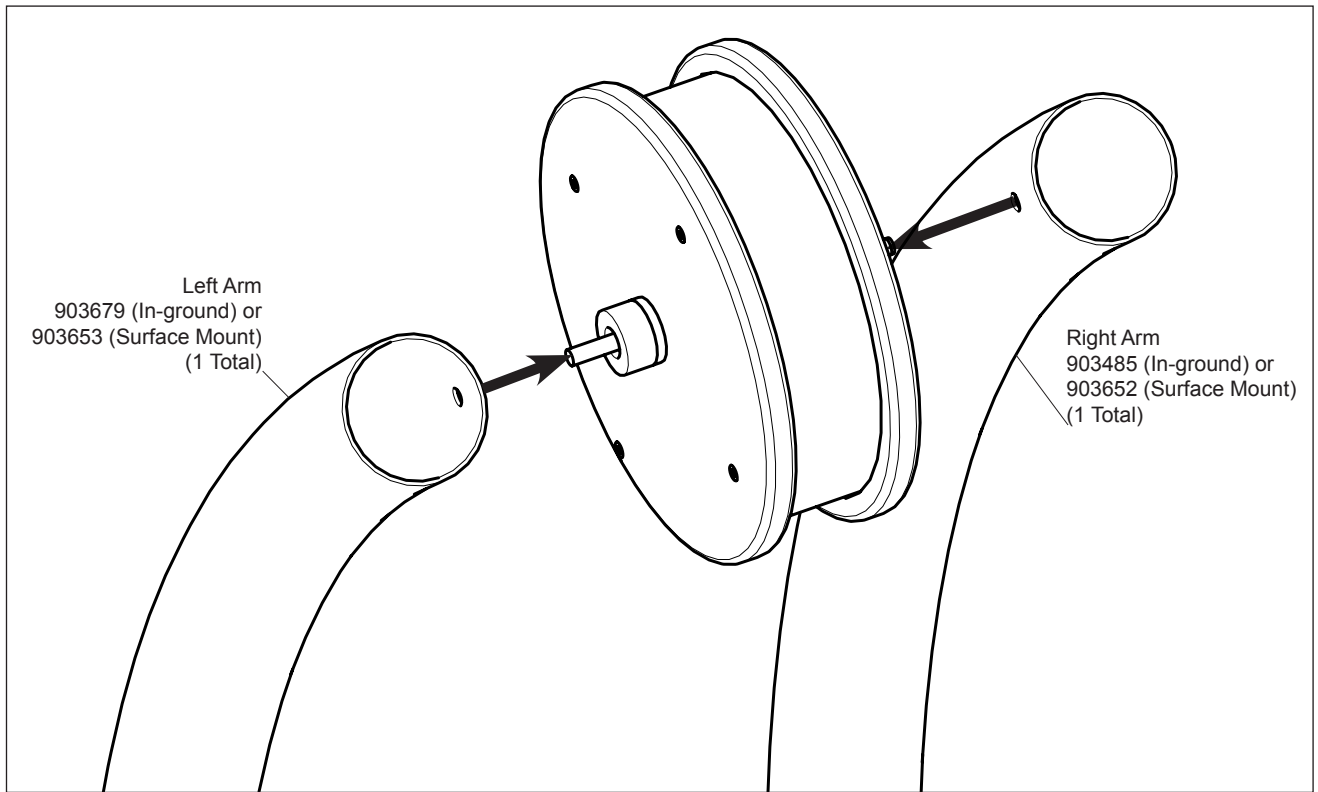

Installation Instructions

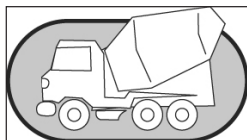
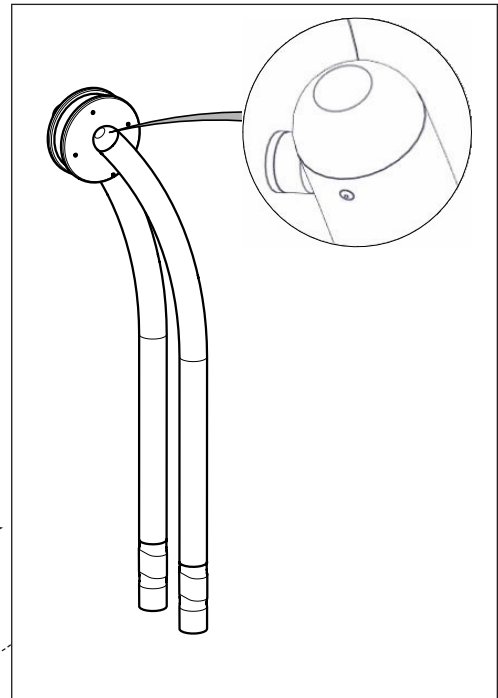
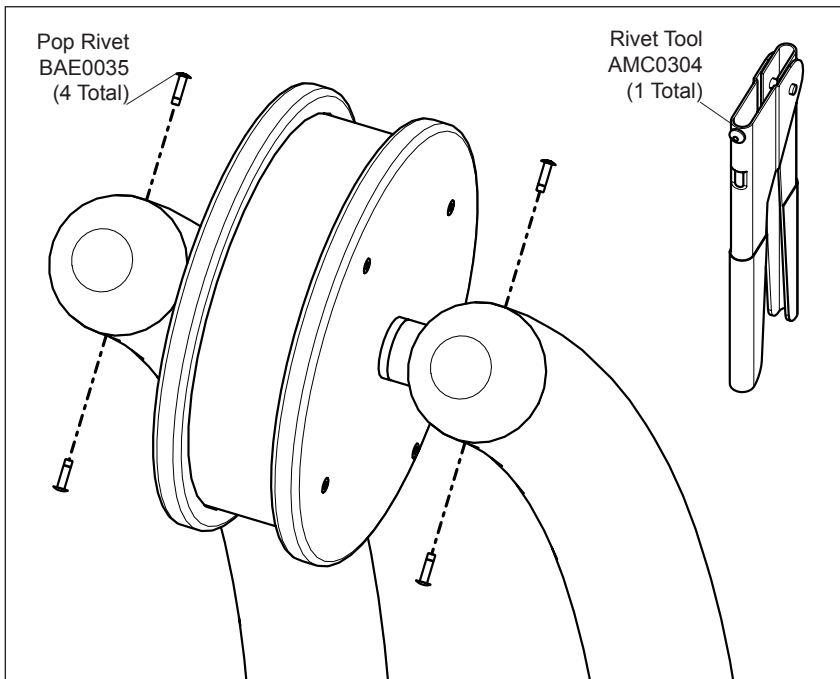
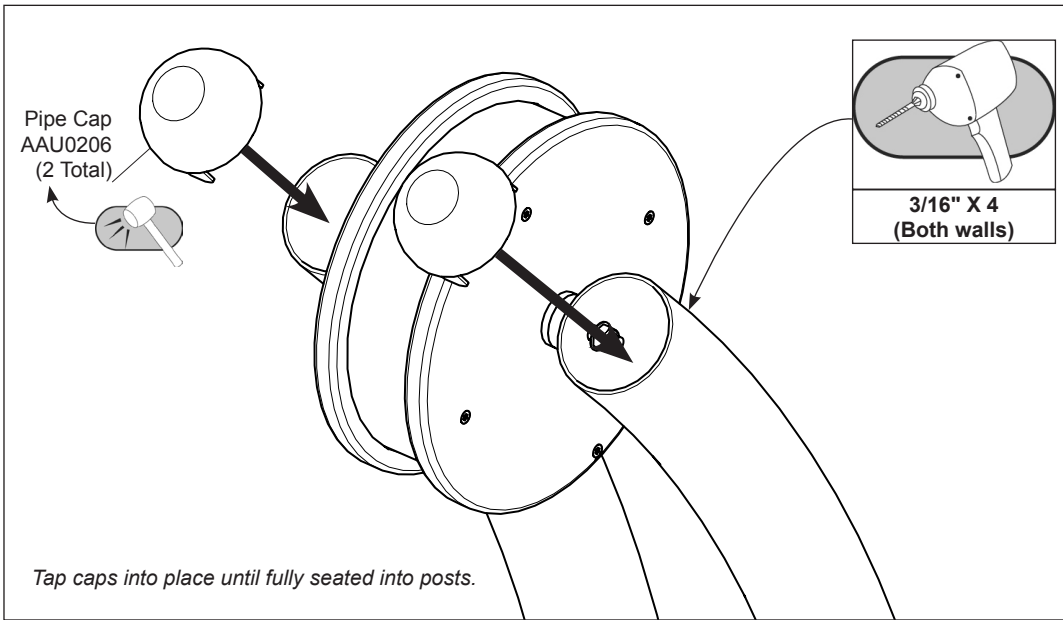

ZZXX0662, 450-5 AND 200203441 - CONCERTO LARGE CABASA IN-GROUND

PART NO.	DESCRIPTION	QTY.
903485	FAB METAL - 3.50" DIA x 69.68" x 15.85" - RIGHT	1
903679	FAB METAL - 3.50" DIA x 69.68" x 15.85" - LEFT	1
903708	CONCERTO - SPIN CABASAS 600mm DIA	1
AAU0206	CAP - 3-1/2" RIVETED CAP	2
BAE0035	RIVET - .1875" x .735" SS POP	4
AMC0304	TOOL - 3/16" STANDARD RIVET GUN	1

ZZXX0662S, 450-5BD AND 200203441 - CONCERTO LARGE CABASA SURFACE MOUNT

PART NO.	DESCRIPTION	QTY.
903652	POST - 35.68" x 18.10" x 8.00" - RIGHT	1
903653	POST - 35.68" x 18.10" x 8.00" - LEFT	1
903708	CONCERTO - SPIN CABASAS 600mm DIA	1
AAU0206	CAP - 3-1/2" RIVETED CAP	2
AMC0304	TOOL - 3/16" STANDARD RIVET GUN	1
BAE0035	RIVET - .1875" x .735" SS POP	4

This page is
intentionally left blank.

Equipment Maintenance

Models ZZXX0662, ZZXX0662S,
450-5, 450-5BD and 200203441

Concerto Large Cabasa In-ground and Surface Mount

Fasteners

- Inspect for loose fasteners.
Tightening torque specifications are:
Bolts and Nuts: Snug tighten and tighten an additional one-half turn.
- Inspect drive rivets to insure they are intact and secure.
- If during the maintenance process a bolt needs to be removed from a part or parts, it will be necessary to apply a drop of liquid thread lock / loctite to the bolt before reinstallation.
- Inspect for missing, worn or broken fasteners. If any missing, worn or broken fasteners are found, refer to the installation instructions for proper replacement fastener. If any damage is detected, barricade equipment to prevent use until repair is completed. Contact your sales representative immediately for a replacement part.

Castings

- Inspect the aluminum castings to insure they are properly secured to the component.
- Visually inspect the castings for cracks or breakage. If any damage is detected, barricade the equipment to prevent use until repair is completed. Contact your sales representative immediately for a replacement part.

Welds

- Inspect all welded joints. If any broken welds are detected, barricade equipment to prevent use until repair is completed. Contact your sales representative immediately for a replacement part.

Finish

- Inspect metal parts for finish damage.
To repair painted surfaces, sand damaged area with sandpaper and wipe clean. Mask area and paint with primer and allow to dry. Paint primed area with color-matching paint and allow to dry. Recoat area with color-matching paint if required. Drying time is approximately 8 hours between coats.

Footings

- Inspect component to be solid in footing and secure. If any damage is detected, barricade equipment to prevent use until repair is completed.

Surfacing

- Refer to the specific surfacing maintenance detail sheet for additional information.

Replacement Parts

- Refer to your installation instructions to obtain replacement part number.
- Contact your sales representative or call Customer Service for a replacement part.

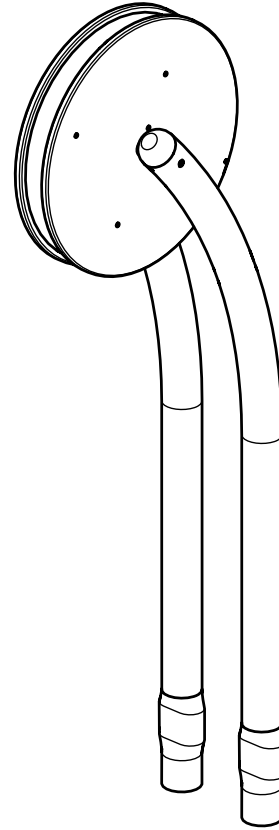

Assembly View (*representative model*)

Inspection Form

- Be sure that you are using a copy of this Inspection Form and not your original.
- Use the Inspection Codes listed below and record condition of equipment at time of examination on the Inspection Checklist.
- Document any item from the Inspection Checklist that will require maintenance along with any corrective action on the Maintenance Schedule.
- Be sure to include appropriate dates and signatures on each section to properly document maintenance procedure.

Inspection Codes	
P = Pass	F = Fail
NA = Not Applicable	

INSPECTION CHECKLIST	Frequency	Inspection Code	Date	Date Repairs Completed
Inspect footing to insure support is secure and footing is not damaged.	Low			
Inspect surfacing to insure proper depth and distribution.	High			
Inspect metal parts for structural and finish damage.	Medium			
Inspect for loose, missing, worn, or broken fasteners.	High			

Inspector: Name (Please Print) _____ Signature: _____ Date: __/__/__

MAINTENANCE SCHEDULE			
Item in Question	Description of Problem	Corrective Action	Date

Repairer: Name (Please Print) _____ Signature: _____ Date: __/__/__