

HAGS Gym with guaranteed fresh air

To exercise is a great way to keep in good health. Both Children and grown ups will keep in better shape by exercising their body. Now the possibility exist to practice the classical strenght, fitness and coordination exercises at an outdoor gym.

HAGS launches four Gym stations, each equipped with three different exercise functions, for use in parks, camping grounds, court yards and other public areas. The stations makes it possible to train various muscle groups and has been developed in cooperation with fitness therapists and physiotherapists. They are adapted to fit people in different ages. The weight load is automaticly adjusted based on the weight of the person exercising.

Accessories:

Sticker with instructions. To be mounted on the back side of the symbol sign for each function.

193100DGB English
193100DFR French
193100DES Spanish
193100DDE German

Each kit contains a complete set for all four stations.



BICO 193 010

Functions:

Chins, Sit Up, Back lift

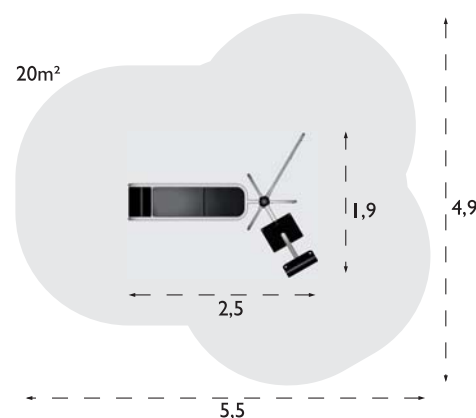
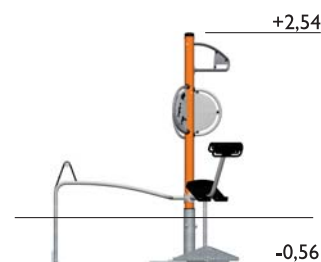

TEKNICAL INFORMATION

Assembly: Preassembled sections.

Anchoring: Sunken foundation.

Inspection/Maintenance: Each week/every season.

Fall protection: Shockabsorbing surface in accordance with EN 1176.

Material: Post and equipment made of hot galvanized, powder coated steel. Foot and back rest made of EkoGrip.

HAGS Aneby AB
Box 133
578 23 Aneby

Phone: +46 (0)380-473 00
Fax: +46 (0)380-451 26
hags@hags.com
www.hags.com

HAGS Gym with guaranteed fresh air

To exercise is a great way to keep in good health. Both Children and grown ups will keep in better shape by exercising their body. Now the possibility exist to practice the classical strenght, fitness and coordination exercises at an outdoor gym.

HAGS launches four Gym stations, each equipped with three different exercise functions, for use in parks, camping grounds, court yards and other public areas. The stations makes it possible to train various muscle groups and has been developed in cooperation with fitness therapists and physiotherapists. They are adapted to fit people in different ages. The weight load is automaticly adjusted based on the weight of the person exercising.

Accessories:

Sticker with instructions. To be mounted on the back side of the symbol sign for each function.

193100DGB English
193100DFR French
193100DES Spanish
193100DDE German

Each kit contains a complete set for all four stations.

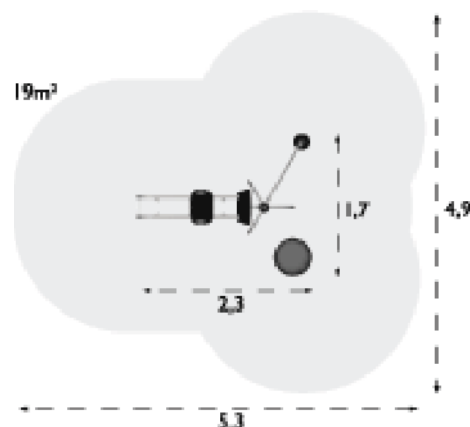
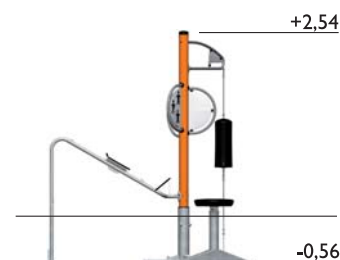

SERRA 193 011

Functions:

Leg Press, Balance, Punch

TEKNICAL INFORMATION

Assembly: Preassembled sections.

Anchoring: Sunken foundation.

Inspection/Maintenance: Each week/every season.

Fall protection: Shockabsorbing surface in accordance with EN 1176.

Material: Post and equipment made of hot galvanized, powder coated steel. Foot and back rest made of EkoGrip. Balance and Boxing ball made of microcell foamed polyurethan. The Balance core is made of weather resistant plywood. The Boxing ball is reinforced with a steel net.

HAGS Aneby AB
Box 133
578 23 Aneby

Phone: +46 (0)380-473 00
Fax: +46 (0)380-451 26
hags@hags.com
www.hags.com

HAGS Gym with guaranteed fresh air

To exercise is a great way to keep in good health. Both Children and grown ups will keep in better shape by exercising their body. Now the possibility exist to practice the classical strenght, fitness and coordination exercises at an outdoor gym.

HAGS launches four Gym stations, each equipped with three different exercise functions, for use in parks, camping grounds, court yards and other public areas. The stations makes it possible to train various muscle groups and has been developed in cooperation with fitness therapists and physiotherapists. They are adapted to fit people in different ages. The weight load is automaticly adjusted based on the weight of the person exercising.

Accessories:

Sticker with instructions. To be mounted on the back side of the symbol sign for each function.

193100DGB English
193100DFR French
193100DES Spanish
193100DDE German

Each kit contains a complete set for all four stations.

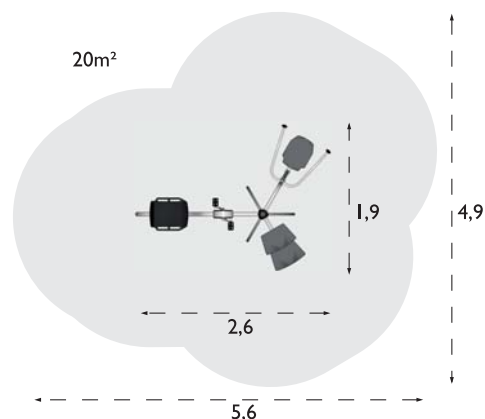
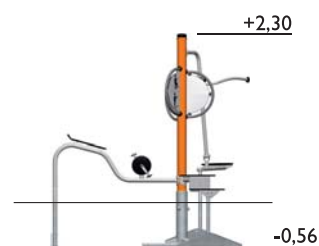
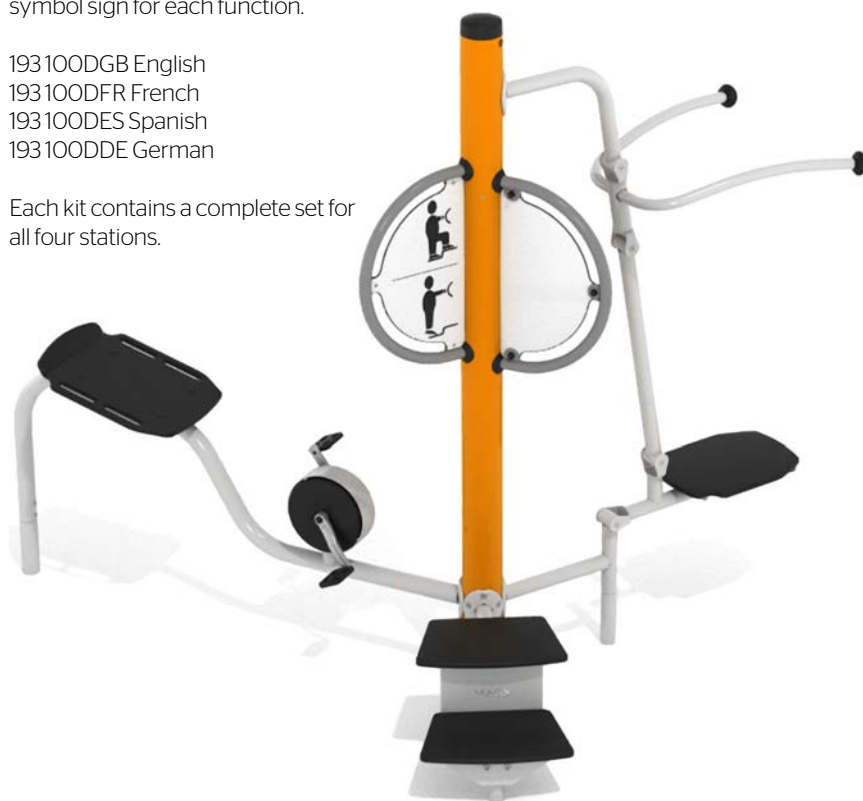

FLEXP 193 012

Functions:

Cycle, Step Up, Pull Down

TEKNICAL INFORMATION

Assembly: Preassembled sections.

Anchoring: Sunken foundation.

Inspection/Maintenance: Each week/every season.

Fall protection: Shockabsorbing surface in accordance with EN 1176.

Material: Post and equipment made of hot galvanized, powder coated steel. Foot and back rest made of EkoGrip.

HAGS Aneby AB
Box 133
578 23 Aneby

Phone: +46 (0)380-473 00
Fax: +46 (0)380-451 26
hags@hags.com
www.hags.com

HAGS Gym with guaranteed fresh air

To exercise is a great way to keep in good health. Both Children and grown ups will keep in better shape by exercising their body. Now the possibility exist to practice the classical strenght, fitness and coordination exercises at an outdoor gym.

HAGS launches four Gym stations, each equipped with three different exercise functions, for use in parks, camping grounds, court yards and other public areas. The stations makes it possible to train various muscle groups and has been developed in cooperation with fitness therapists and physiotherapists. They are adapted to fit people in different ages. The weight load is automaticly adjusted based on the weight of the person exercising.

Accessories:

Sticker with instructions. To be mounted on the back side of the symbol sign for each function.

193100DGB English
193100DFR French
193100DES Spanish
193100DDE German

Each kit contains a complete set for all four stations.

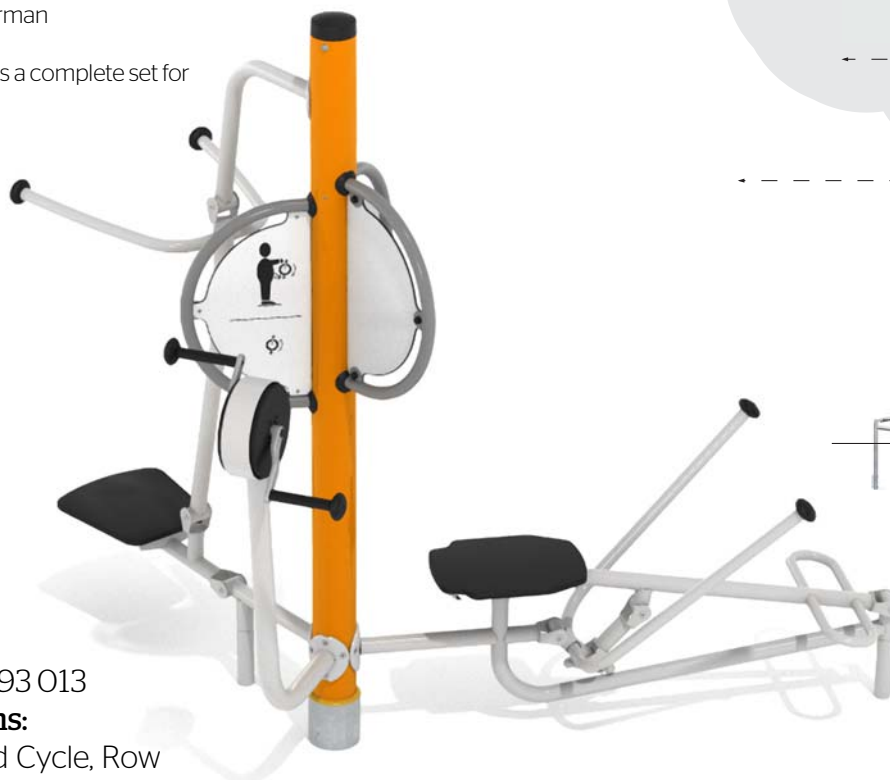
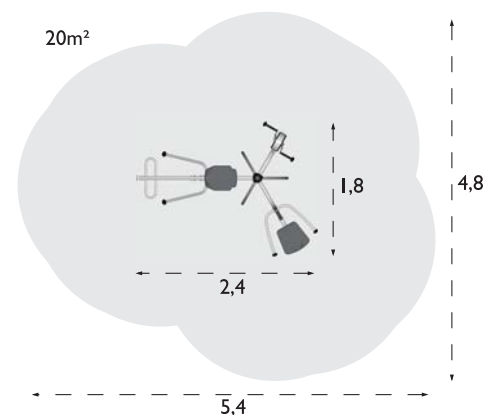

TIBAS 193 013

Functions:

Dip, Hand Cycle, Row

TEKNICAL INFORMATION

Assembly: Preassembled sections.

Anchoring: Sunken foundation.

Inspection/Maintenance: Each week/every season.

Fall protection: Shockabsorbing surface in accordance with EN 1176.

Material: Post and equipment made of hot galvanized, powder coated steel. Foot and back rest made of EkoGrip.

HAGS Aneby AB
Box 133
578 23 Aneby

Phone: +46 (0)380-473 00
Fax: +46 (0)380-451 26
hags@hags.com
www.hags.com